

Vandal Resistant CP Lead Safe™ J/V Wall Top Assembly Cold

PRODUCT CODES

- 174.01.02.01

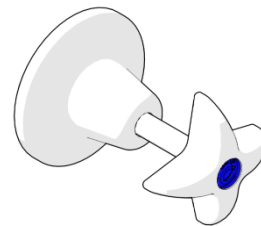

SPECIFICATIONS

- Chrome plate finish for easy cleaning and durability.
- Simple servicing and readily available parts.
- Tough vandal resistant handle that has a unique locking system.
- Quality controlled. Every tap is tested.
- Lead Safe™ brass construction*

IMPORTANT: All Vandal Resistant Jumper valve taps are tested in accordance with AS/NZS 3718 and leave our premises in good working order.

*As 'lead free' is not currently defined by law in Australia and New Zealand, we have based our definition of Lead Safe™ on the requirements of s1417 of the USA's Safe Drinking Water Act (SDWA) and the relevant US standards NSF61 / NSF372. The SDWA defines 'lead free' as "not more than a weighted average of 0.25% lead when used with respect to the wetted surface of pipes, pipe fittings, plumbing fittings and fixtures".

TECHNICAL DATA

Inlet	5/8" BSP - Male	
Outlet	N/A	
Headwork	Jumper Valve	
Working Pressure Range (kPa)	Min	50
	Max	500
Working Temperature Range (°C)	Min	5
	Max	60
Nominal Flow Rate (LPM)	N/A	
Construction	Brass	
Finish	Chrome	

NOTE: Galvin Engineering continually strive to improve their products. Specifications may change without notice.

TOOLS REQUIRED

- Spanner or adjustable crescent
- Key Spanner (supplied)

PRE-INSTALLATION

DIMENSIONS

Note: Before installation, all lines must be flushed. We recommend that a line strainer be installed prior to drinking taps to eliminate any foreign material.

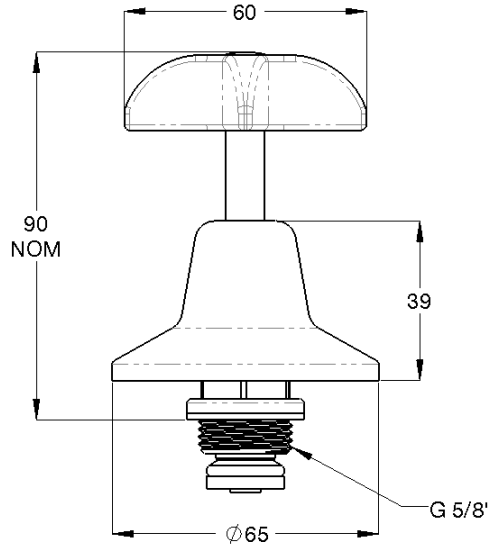

INSTALLATION

IMPORTANT: Galvin Specialised products must be installed in accordance with these installation instructions and in accordance with AS/NZS 3500, the PCA and your local regulatory requirements. Water and/or electrical supply conditions must also comply to the applicable national and/or state standards. Failing to comply with these provisions shall void the product warranty and may affect the performance of the product.

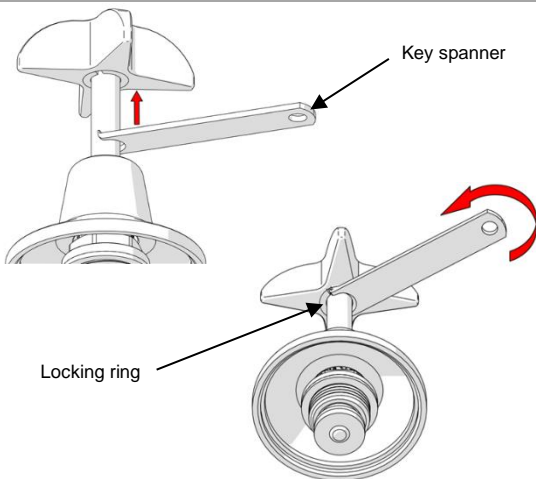

1. Remove locking ring

- Using supplied key spanner, unscrew the handle assembly locking ring as shown.

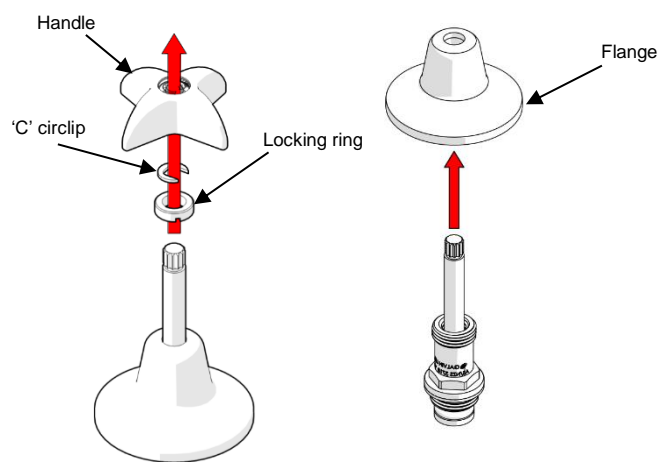

2. Disassemble

- Remove the handle, then 'C' circlip and locking ring.
- Unscrew the flange.

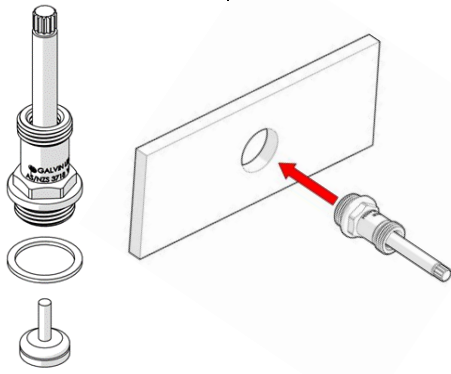

3. Fit top assembly

- Fit top assembly ensuring the tap washer and jumper valve is in place.

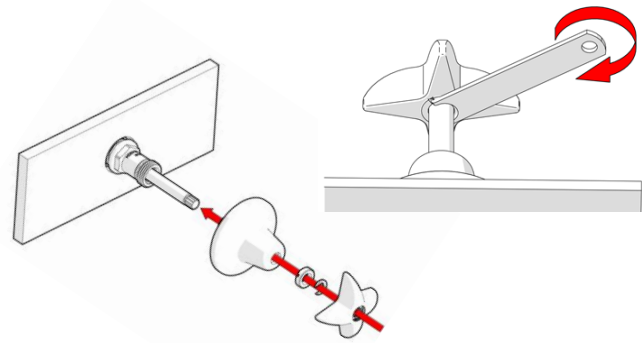

4. Re-assemble

- Fit the assembly components by reversing steps 2 & 1 as shown.

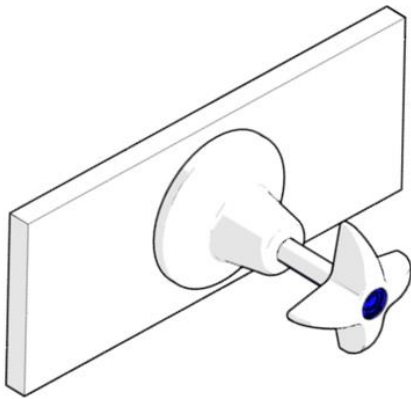

5. Testing

Once the assembly has been installed, test for leaks and correct operation.

TROUBLESHOOTING

PROBLEM	CAUSE	RECTIFICATION
Water is not flowing from tap	Water supply is turned off	Turn on water supply
Assembly is leaking	The supplied tap washer wasn't installed.	Repeat installation steps ensuring the tap washer is correctly in place
Tap is leaking	Worn jumper valve.	Remove the top assembly and replace the jumper valve

WARRANTY

The warranty set forth herein is given expressly and is the only warranty given by the Galvin Engineering Pty Ltd. With respect to the product, Galvin Engineering Pty Ltd makes no other warranties, express or implied. Galvin Engineering Pty. Ltd. hereby specifically disclaims all other warranties, express or implied, including but not limited to the implied warranties of merchantability and fitness for a particular purpose.

Galvin Engineering Pty Ltd products are covered under our manufacturer's warranty available for download from www.galvinengineering.com.au Galvin Engineering Pty Ltd expressly warrants that the product is free from operational defects in workmanship and materials for the warranty period as shown on the schedule in the manufacturer's warranty. During the warranty period, Galvin Engineering will replace or repair any defective products manufactured by Galvin Engineering without charge, so long as the terms of the Manufacturer's warranty are complied with.

The remedy described in the first paragraph of this warranty shall constitute the sole and exclusive remedy for breach of warranty, and Galvin Engineering Pty Ltd shall not be responsible for any incidental, special or consequential damages, including without limitation, lost profits or the cost of repairing or replacing other property which is damaged if this product does not work properly, other costs resulting from labour charges, delays, vandalism, negligence, fouling caused by foreign material, damage from adverse water conditions, chemical, electrical or any other circumstances over which Galvin Engineering has no control. This warranty shall be invalidated by any abuse, misuse, misapplication, improper installation or improper maintenance or alteration of the product.